

Features

- No External Power Required
- 150mA Trip Point
- Compatible up to 200 Amps
- Real time operation
- Miniature size
- Reusable
- User-friendly
- Low cost

Applications

- Energy Audits
- Equipment Monitoring
- Heating and cooling systems
- Fans
- Power supply on/off
- Monitoring gas, water or electric pumps
- Time studies



The Motor101 measures and records on and off status changes for motors or other equipment drawing up to 200 Amps. The state change occurs when the current switch exceeds the 150mA set point. This allows for most basic equipment to be monitored.

The current switch monitors whether there is current passing through a wire around which it is clamped. When the current exceeds 150mA's, the output changes and provides a voltage for the Motor101 to measure.

All data is date and time stamped and the duration of the on or off status is also provided (see graph screen shot below).

The LED on the Motor101 blinks at the user specified reading rate. The device can hold up to 32,767 state changes, but memory will only be used if the status has changed. The device can be programmed to check for status changes every 1 second, up to once every 12 hours.

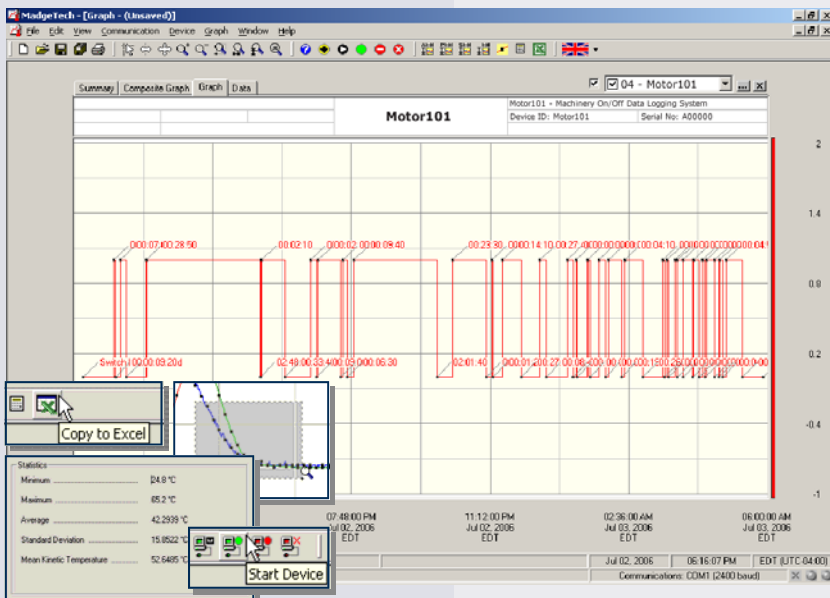

MadgeTech Data Recorder Software displays on and off status in an easy to use graph.

The Windows®-based software package allows the user to effortlessly collect, display and analyze data. A variety of powerful tools allow you to examine, export, and print professional looking data with just a click of the mouse.

- Tabular Data View
- Summary View
- Statistics
- Data Annotation
- Multilingual
- Export to Excel®

Click [MadgeTech Software](#) for more information or to download the software.

MOTOR101 SPECIFICATIONS*

Amperage Range: 0.15—200 Amps
Trip Point: 0.15A (150mA) fixed
 (200mA AC for 50Hz operation)
Status Output (max.): N.O. 1.0A@30VAC/DC
Housing: Split Core
Measurement Capacity: 13,107 state changes
Memory Modes: Stop when full, wrap around
 (if enabled)
Memory: Non-volatile, solid state memory.
 Retains data if battery becomes
 discharged
Time Resolution: 1 second (reading rate dependent)
Reading Rate: 1 reading every second to 1 every 12
 hours
Time Accuracy: ±1 minute/month at 20°C
 (RS232 cable not in use)
Visual Indicator: LED flashes at selected reading rate.

Battery Type: 3.6V lithium battery, included;
 user replaceable
Battery Life: 1 year typical life at 25°C
Computer Interface: PC serial or USB (interface cable required);
 2,400 baud.
Software: XP SP3/Vista/Windows 7
Operating Environment: -15 to +40°C, 10 to 90%RH non-condensing
DIMENSIONS:
Data Logger: 1.4" x 2.5" x 0.6" (36mm x 64mm x 16mm)
Current Switch: See diagram below
Weight (without IFC200): 4oz (113 g)
Weight (with IFC200): 9oz (255 g)
Material: ABS plastic (data logger)

BATTERY WARNING: FIRE, EXPLOSION, AND SEVERE BURN HAZARD. DO NOT RECHARGE,
 DISASSEMBLE, HEAT ABOVE 212°F,

DIMENSIONS

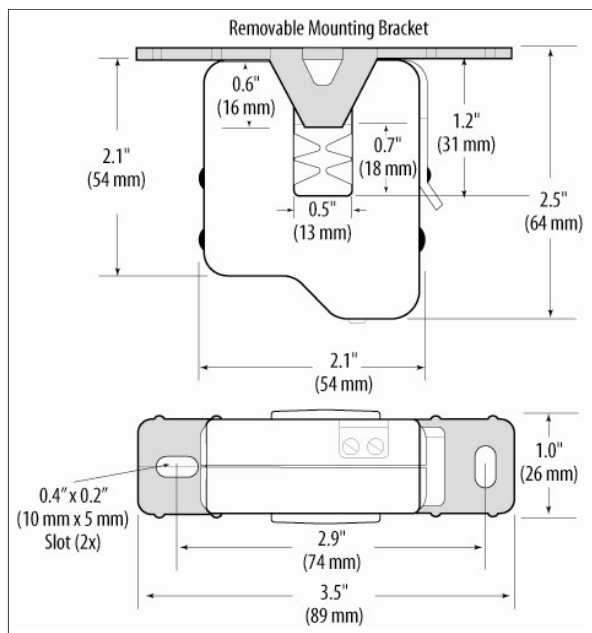

WIRING EXAMPLE

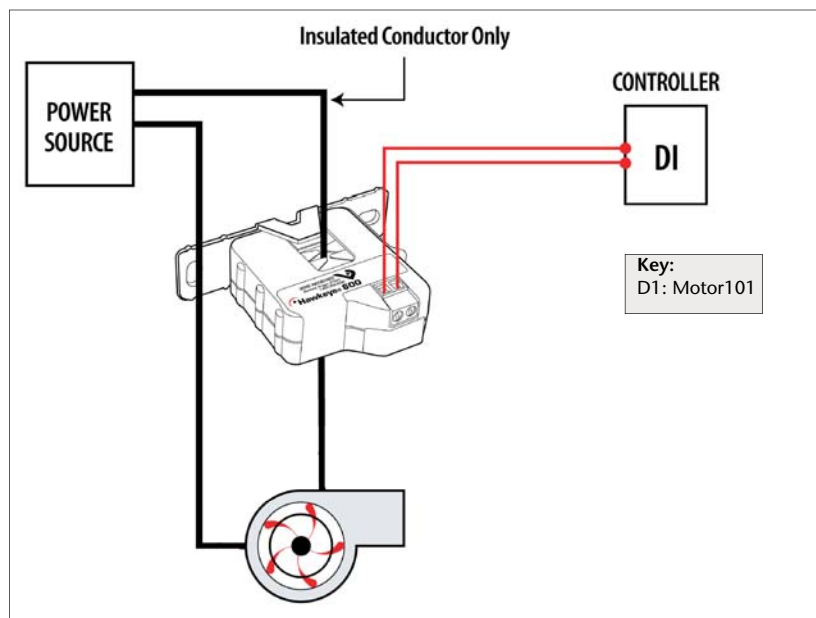

*SPECIFICATIONS ARE SUBJECT TO CHANGE WITHOUT NOTICE.
 SPECIFIC WARRANTY AND REMEDY LIMITATIONS APPLY.
 CALL 1-603-456-2011 OR GO TO WWW.MADGETECH.COM FOR DETAILS.

ORDERING INFORMATION

Model	Description	Price (U.S.)
Motor101-C	Machinery On/Off Status Data Logging System (includes data logger, current switch and IFC200 interface cable)	\$249.00
Motor101-NC	Machinery On/Off Status Data Logging System (data logger and current switch)	\$199.00
LTC-7PN	Replacement battery for Motor101	\$10.00

ASK ABOUT OUR OTHER DATA RECORDERS

Temperature	Pulse/Event/State
Humidity	Low Level Current
Pressure	Low Level Voltage
pH	RF Transmitters
Level	Intrinsically Safe
Shock	Spectral Vibration
LCD Display	



DOC-1188009-00 REV C 2010.06.28